

CR17335SL Brief Datasheet

Lithium Manganese Dioxide Battery

1 BASIC SPECIFICATION

(Typical values relative to cells stored for one year or less at +30°C max.)

Nominal capacity (at 1mA, +23 °C) * ¹	1500mAh
Nominal voltage	3.0V
Standard discharge current	1mA
Maximum continuous current	1000mA
Maximum pulse current * ²	3000mA
Operating temperature range * ³	-40 °C - +85 °C
Storage temperature (recommended)	+30 °C Max
Weight	20g

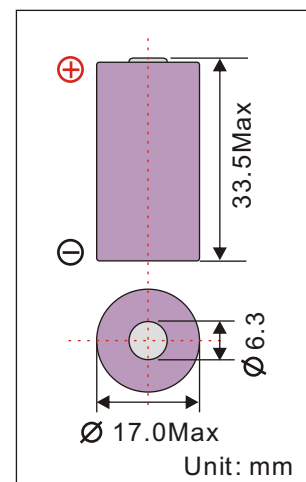

Note:

- *¹ At 1mA discharge current to 2.0V cut-off, +23 °C. The capacity restored by the cell varies according to current drain, temperature and cut-off.
- *² The readings may vary according to the pulse characteristics, the temperature, and the cell's previous history.
- *³ Operation above ambient temperature range may lead to reduced capacity and lower voltage readings at the beginning of pulses. Consult EEMB.

2 MAIN FEATURES

- Best suit for high current discharge for both continuous and pulse current.
- Light Weight, High Voltage and High Energy Density.
- Excellent Stable Discharge Characteristics and Outstanding Temperature Characteristics.
- Excellent Leakage Resistance and Excellent Long-term Reliability.

3 ELECTRICAL CHARACTERISTICS

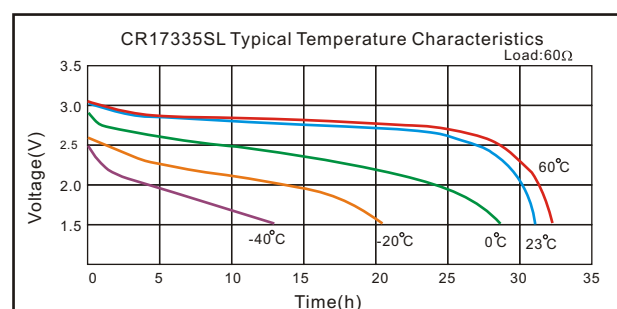
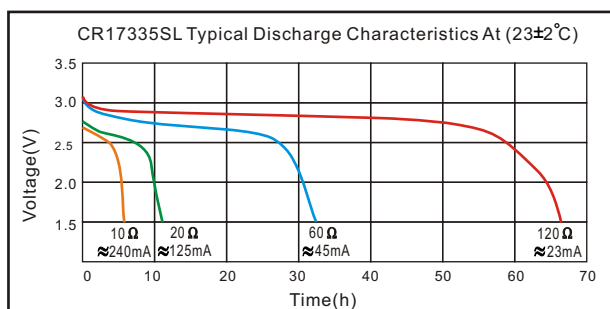

Spiral Structure Laser-sealing

Note: Any representations in this brochure concerning performance, are for informational purposes only and are not construed as warranties either expressed or implied, of future performance.