

# NC-1/3AA180 *Brief Datasheet*

## Nickel Cadmium Battery

### 1 Dimension

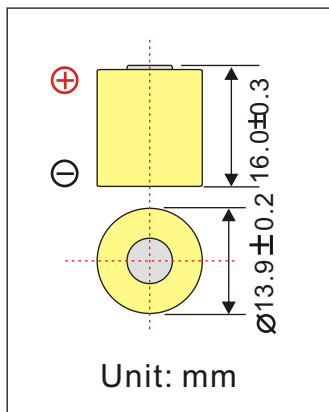

### 3 Electrical Characteristics

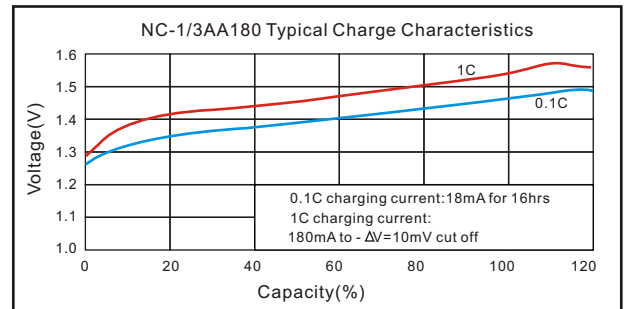

### 2 Basic Specification

Nominal Voltage		1.2V	
Nominal Capacity*	Typical	200mAh (0.2C discharge)	
	Minimum	180mAh (0.2C discharge)	
Charge	Standard	18mA for 16hrs	
	Fast	180mA for Approx.75mins	
Internal Impedance		≤70mohms	
Life Cycles		500 cycles	
Operation Temperature	Charge	Standard	0°C to 40°C
		Fast	10°C to 40°C
	Discharge		-10°C to 50°C
	Storage	<1year	-10°C to 30°C
<3month		-10°C to 40°C	
Discharge cut-off voltage		1.0V	
Weight		Approx. 8g	

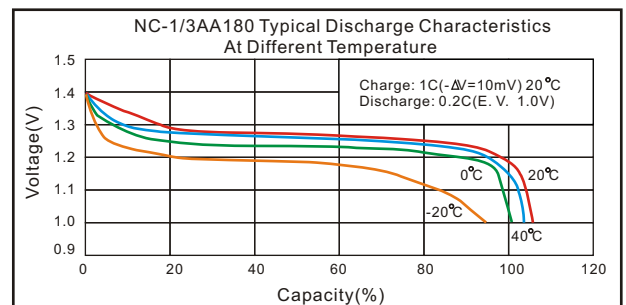
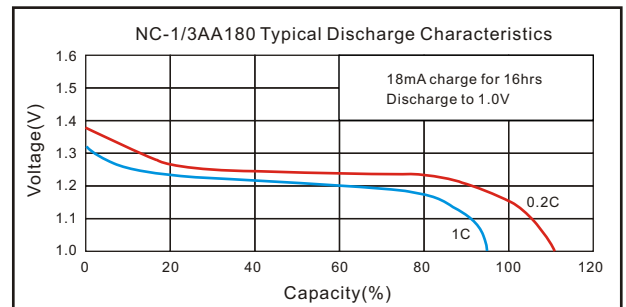

Note:\*Typical values relative to cells stored for less than 3 months or less at 30°C max.

\*After charging at 0.1C for 16 hours.

\*We recommend cells or batteries are charged once every 3 months.

# Ni-Cd

Note: Any representations in this brochure concerning performance, are for informational purposes only and are not construed as warranties either expressed or implied, of future performance.